

fragment line

Design by
Dechem Studio

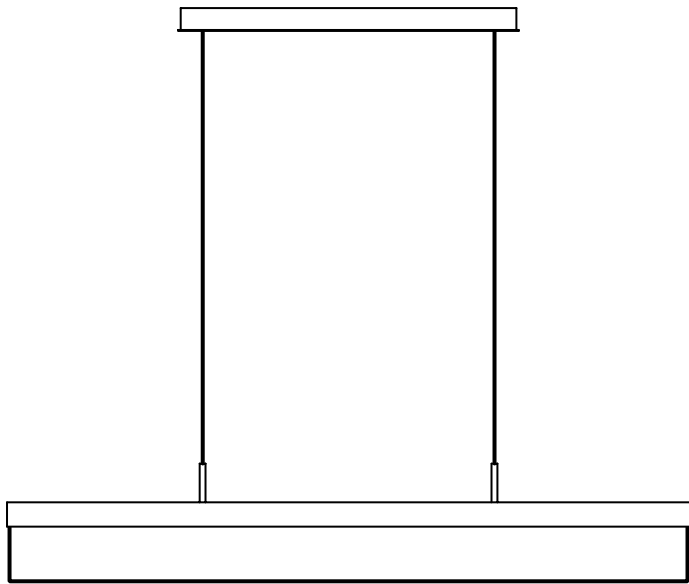

loomma

bomma.cz

TECHNICAL SHEET
FOR PENDANT LIGHT FIXTURES

FRAGMENT LINE

pendant

Design by
Dechem Studio

Handmade glass attributes

Each Fragmentglass panel is uniquely crafted by stacking glass shards in a melting mould. This process introduces natural elements like bubbles and iron traces, which enhance the panel's aesthetic. While designers control the colour, shard size, and format, the final appearance may vary due to the unpredictable melting process. These variations are intentional and add to the panel's uniqueness.

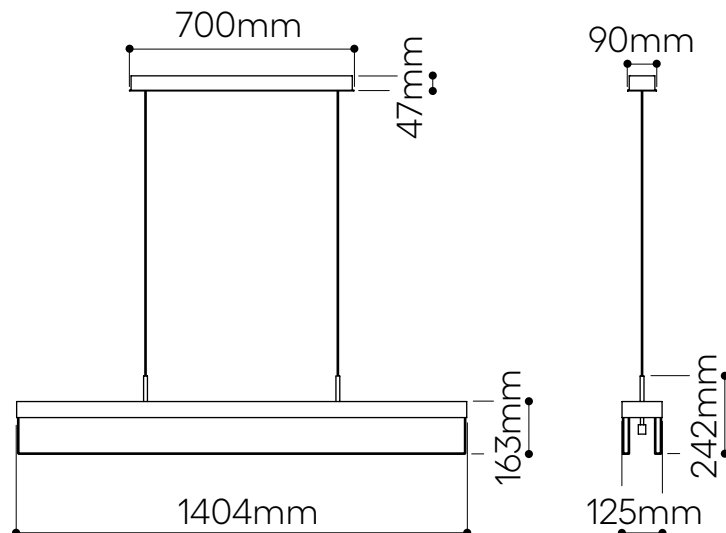

LIGHTING DESCRIPTION

Size	1404 x 125 mm, H 242 mm 55,3 x 4,9 inch, H 9,5 inch
Cable	black textile braid cable 2,5 m / 98,4 inch
Weight	+32,3 kg / 71,2 lb
Glass	Fragmentglass in black and white color
Material	Aluminium, Stainless steel
Mounting	Brushed Silver, Brushed Gold
Protection	IP34, Over Current, Over Voltage, Over Temperature, Short Circuit
Nominal voltage	100-305V AC 47-63Hz / 142-431V DC 90-130V AC 47-63Hz / 180-264V AC 47-63Hz max. consumption with reserved capacity 150 W
AC current	< 1A / 230 VAC
Working Temperature	5-47°C
Working Humidity	20~80% RH non-condensing
Class	I. EU / I. USA

LIGHT SOURCE

Type	LED strip 14 W / m
Base	CREE Tunable White 5 years warranty
Brightness	2400 lm / m
Voltage/Current/Consumption	24V DC / 4A / 96W
Temperature	1850-4000 K linear
Color index	Up to 93 depends on selected temp.
Dimming	TRIAC, DALI-2, CASAMBI

PACKAGING

Material	Cardboard
Size	1489 x 209 x 413 mm 58,6 x 8,2 x 16,3 inch

Origin: traditionally produced in the Czech Republic
Intellectual property license holder: Bomma Czech Republic (EU)
Represented by BMRC group s.r.o.

